

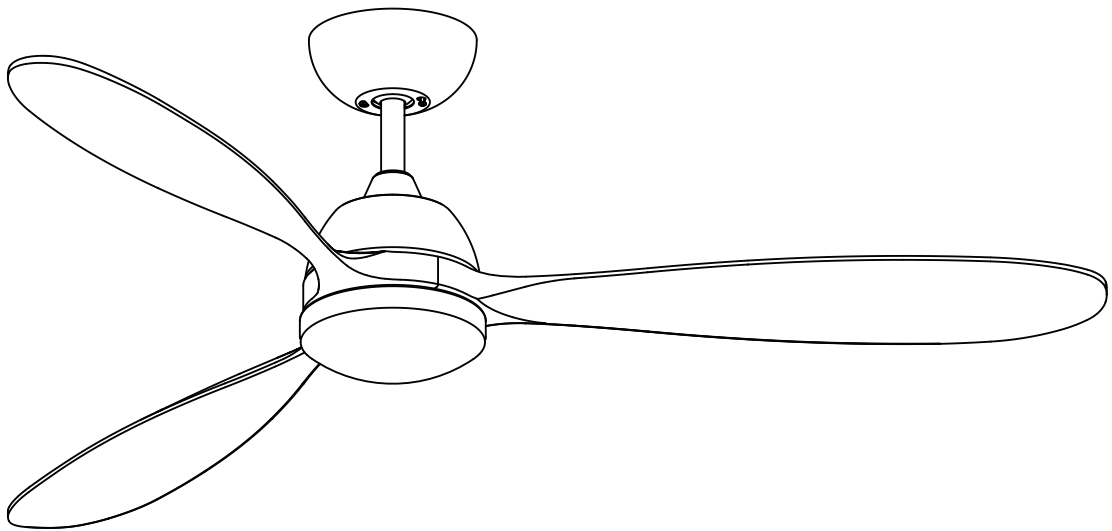

Aesthetics of Wind
Since 1985



**MODEL : DESIGN
VITA**

Owners Manual

Net weight

KGS.
LBS.

WARNING : Read and follow these instructions carefully and be mindful of all warnings shown throughout.

READ AND SAVE THESE INSTRUCTIONS

WARNING : TO REDUCE THE RISK OF FIRE, ELECTRICAL SHOCK, OR INJURY TO PERSONS, PLEASE OBSERVE THE FOLLOWING :

- 1]. To ensure the success of the installation, be sure to read the instructions and review the diagrams thoroughly before beginning.
- 2]. **To avoid possible electric shock, be sure electricity is turned off at the main power box before wiring.**
All electrical connections must be made in accordance with local codes, ordinances and/or the National Electric Code. If you are unfamiliar with the methods of installing electrical wiring and products, require the services of a qualified and licensed electrician as well as someone who can check the strength of the supportive ceiling members and make the proper installations and connections.
- 3]. Make sure that your installation site will not allow rotating fan blades to come in contact with any object when fan is in operation. **Blades must mounted at least 7 feet from the floor.**
- 4]. If possible, mount ceiling fan on a ceiling joist - the joist must be able to support the motion and weight of the moving fan. If the fan will be mounted on a ceiling outlet box, a 4" x 2-1/8" deep METAL octagon box is required ; one UL listed as " suitable for fan support ". The box and its supporting members must not be able to twist or work loose. **DO NOT USE PLASTIC BOXES.** Installation on a concrete ceiling should be performed by qualified personnel.
- 5]. Blades should be attached after motor housing is hung and in place. Fan motor housing should be kept in carton until ready to be installed to protect its finish. If you are installing more than one ceiling fan, make sure that you do not mix fan blade sets.
- 6]. After making electrical connections, spliced conductors should be turned upward and pushed carefully up into outlet box. The wires should be spread apart with the grounded conductor and the equipment - grounding conductor on one side of the outlet box and the " HOT " wires on the opposite side.
- 7]. Electrical diagrams are for reference only. Light kits that are not packed with the fan must be CE listed and should be installed per the light kit's installation instructions.
- 8]. After fan is completely installed, check to make sure that all connections are secured to prevent fan from falling and/or causing damage or injury.
- 9]. The fan can be made to work immediately after installation. There is no need to oil your fan.
The motor has permanently lubricated bearings.
- 10]. The fan must be turned off and stopped before reversing fan direction.
- 11]. **The fan is for downrod mount only.**
- 12]. **This fan is reversible.**
- 13]. **This fan is controlled by remote.**
- 14]. **This fan is suitable for indoor use.**

Unpack and inspect fan carefully to be certain all contents are included.

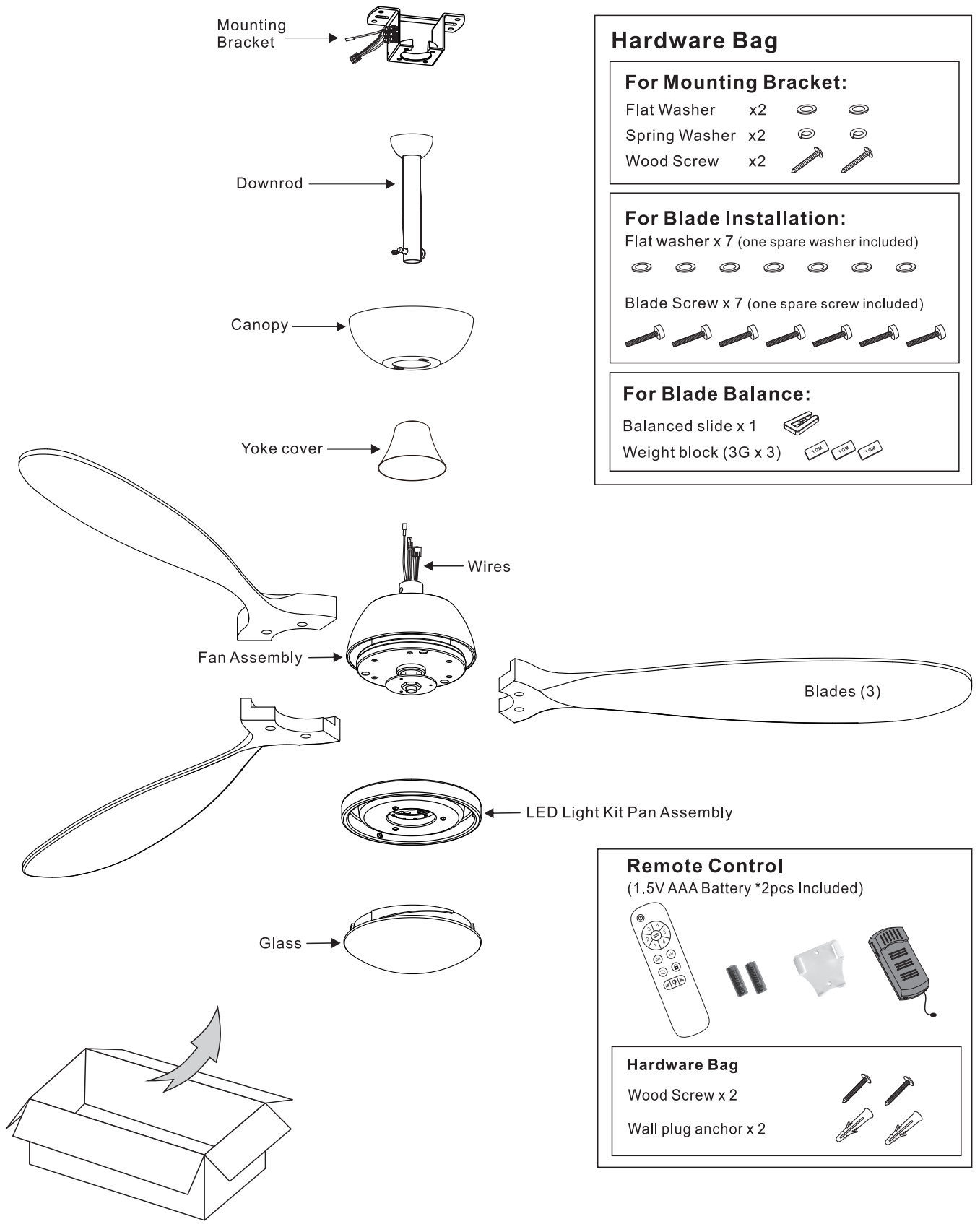

Unit pack / all in one box

WARNING: blades should be at least 7 feet from floor

Note 1:

Turn off power at breaker box to avoid possible electrical shock.

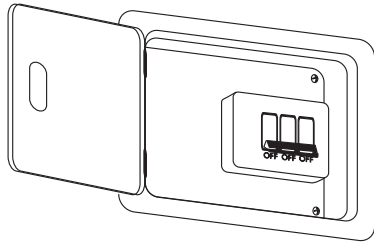

Note 2:

Use metal outlet box suitable for fan support. Outlet box must support 35 lbs min.

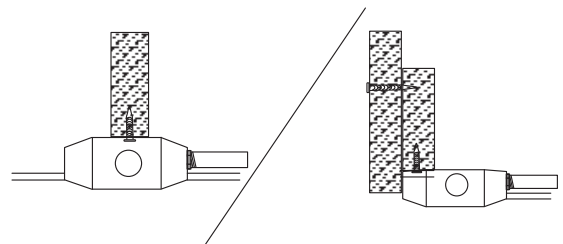

1. HANGING SYSTEM INSTALLATION

1A. Installing mounting bracket to ceiling outlet box

- 1 Install mounting bracket to outlet box on ceiling by using screws included with the outlet box and washers from the hardware bag.
- 2 Loosen the screws at mounting bracket.

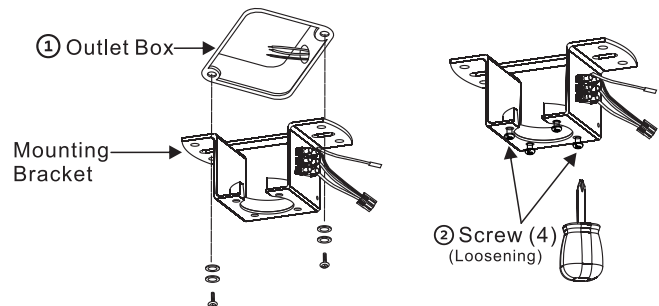

2. DOWNROD INSTALLATION

2A. Installing Downrod and Yoke

- 1 Loosen the jam screw from the hanging ball and pull it down, remove the pin from downrod and keep it for step 6.
- 2 Remove the hanging ball and keep it for step 6.
- 3 Remove cross pin and cotter pin from downrod and keep them for step 8.

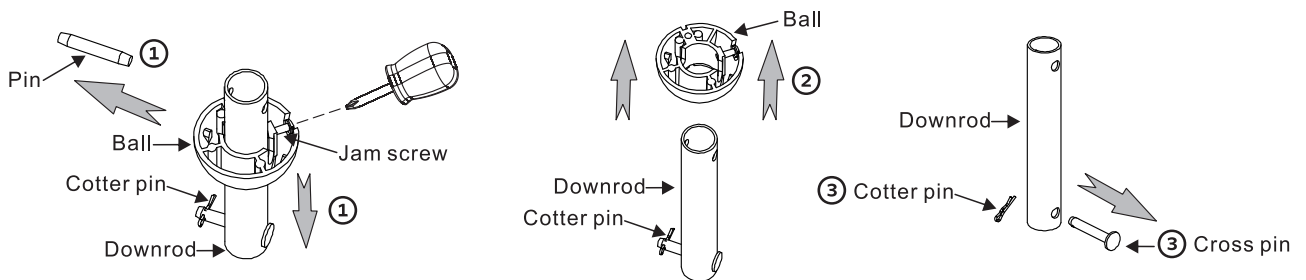

- 4 Loosen 2 downrod jam screws at yoke.
- 5 Insert downrod through canopy and yoke cover, and feed motor lead wires through downrod.

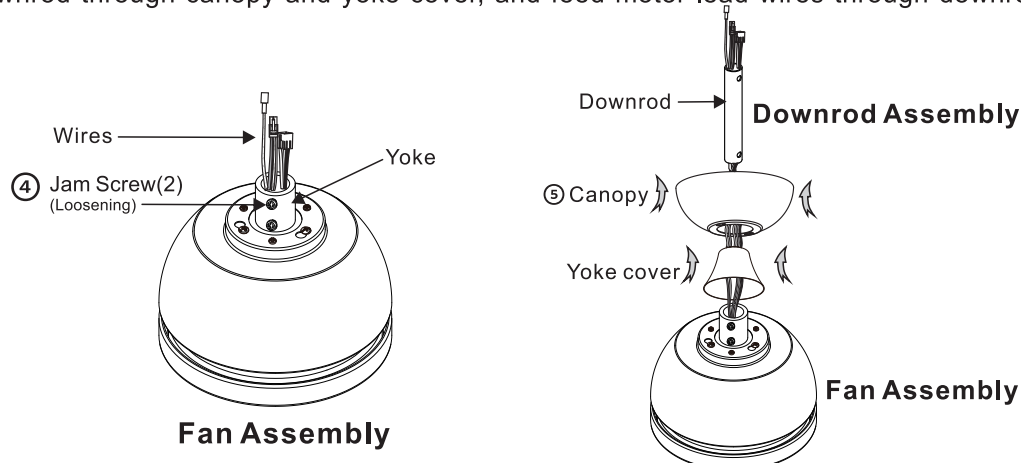

- ⑥ Insert hanging ball through downrod and insert the pin back into the downrod.
(Removed from step ① and ②)
- ⑦ Tighten the jam screw back to hanging ball and make sure it is tight. (Loosen from step ①)
- ⑧ Insert downrod assembly into yoke, insert the cross pin through yoke & downrod and secure with cotter pin. (Removed from step ③)
- ⑨ Tighten both downrod jam screws to further secure downrod. Pull down the yoke cover to cover yoke.

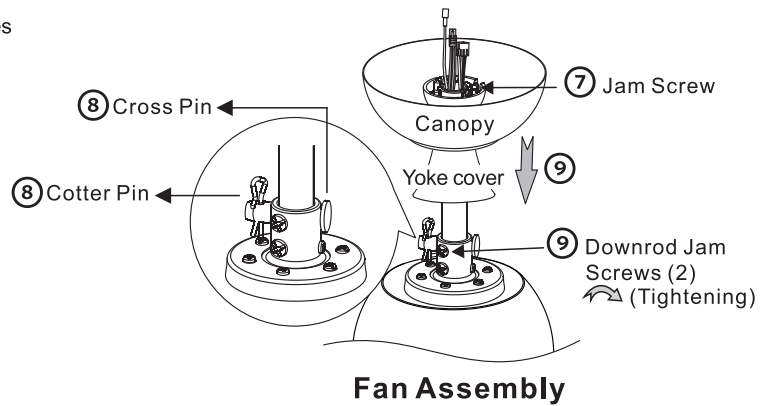
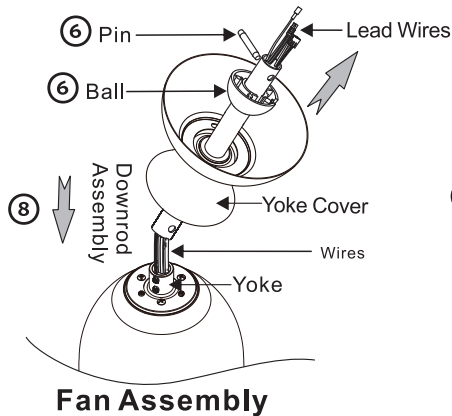

3. HANGING THE FAN ONTO MOUNTING BRACKET

- ① Lift fan assembly onto mounting bracket.

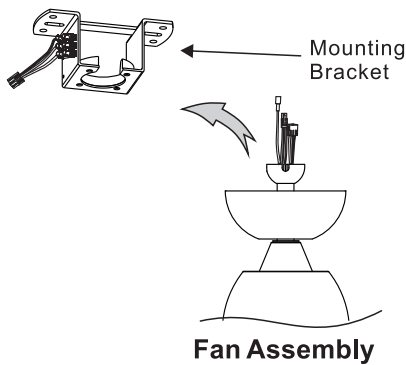

- ② Rotate fan so that the groove on the ball engages the ridge in the mounting bracket.

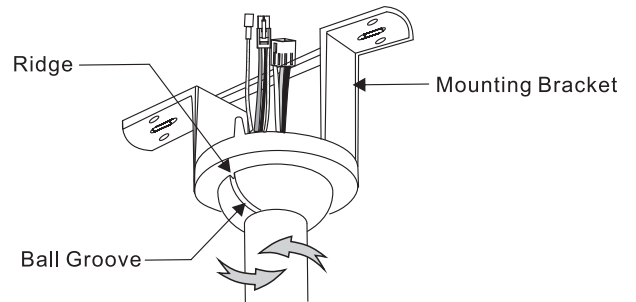

4. WIRE CONNECTION

4-1. Verify that serial Number & Model Number match on the Receiver and Transmitter NOTICE :

Many remote sets for DC fans look the same. This remote set is pre-paired and labeled at the factory, please note the following before operation:

- 1a. The Remote Model Number on transmitter and receiver must be the same.
- 1b. The Remote Serial Number will be the same on a pre-paired remote set. If it is different, it will need to be paired (See page 10)
2. The Fan Model Number label must be the same as the fan's model number in front page (3VT52) for proper operation. (There is no Fan Model Number on transmitter.)
3. Do not mix the remote sets if you are installing more than one fan.

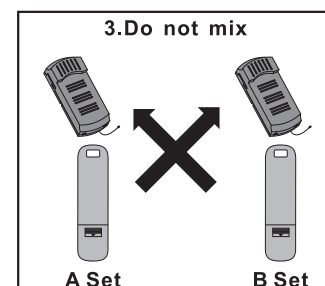
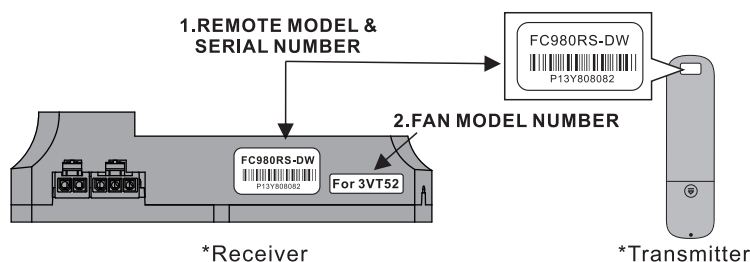

4-2. Insert receiver into mounting bracket

NOTE: Do not squeeze all the wires while inserting the receiver into the mounting bracket.

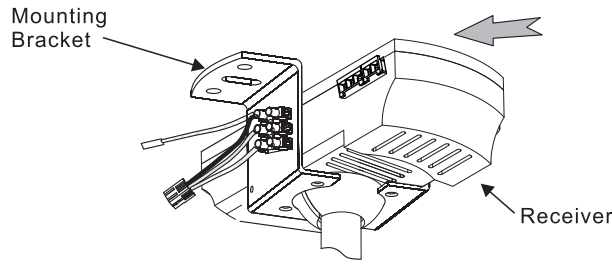

4-3. Making electrical wire connection

Follow diagram below and make sure that all exposed wires are secured inside terminal block and AMP connector.

Note : Wires from house may vary in color and may not include ground wire (yellow/ green).

*Brown wire from house to terminal block(L).

*Blue wire from house to terminal block(N)

*Ground wire from house to yellow/green wires from Mounting Bracket.

*Connect 3P AMP from hanging bracket to Receiver.

*Connect 3P AMP & 2P AMP from Fan to Receiver.

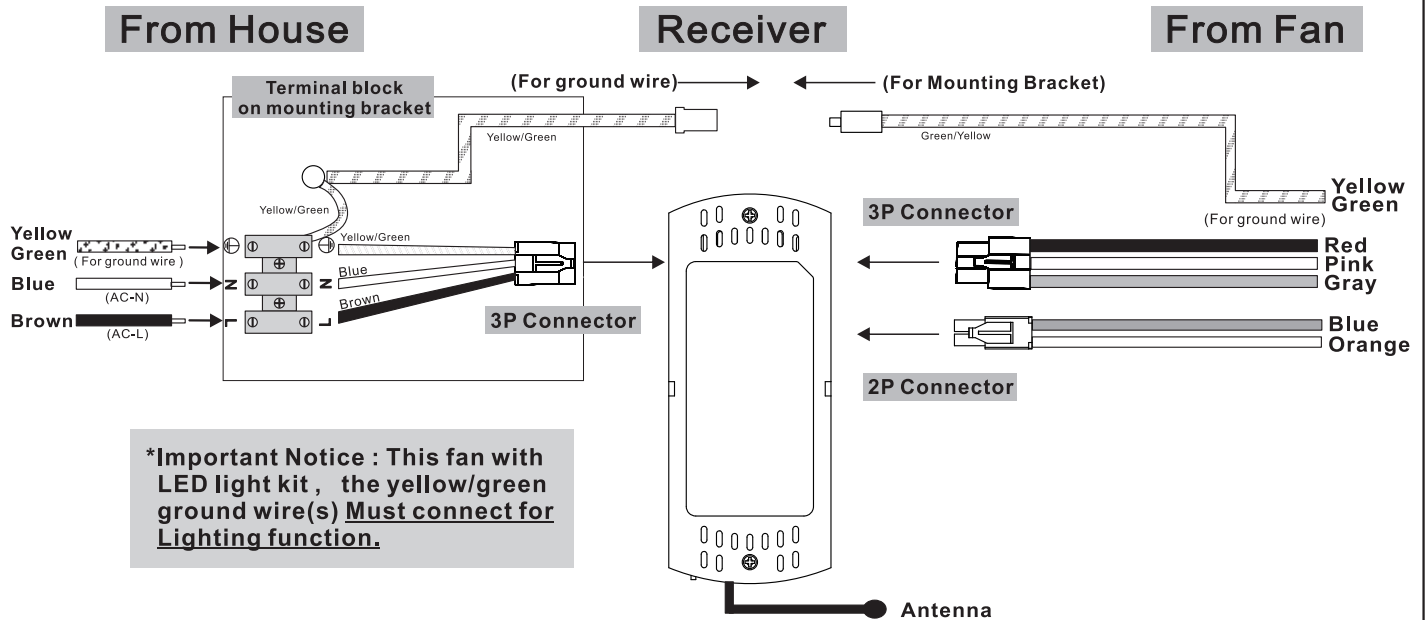

“ Special note: All Yellow/green grounding wires, from Fan Assembly / Mounting bracket, must be well attached to House Ground/Earth to prevent flickering of LED. ”

5. CANOPY INSTALLATION

Note: Two screws are pre-installed on mounting bracket for canopy installation.

- ① Push up canopy until two screws pre-screwed on mounting bracket are engaged with two key holes on canopy.
- ② Rotate canopy slightly until two pre-installed screw heads are engaged in the narrow end of key holes.
- ③ Tighten both screws.

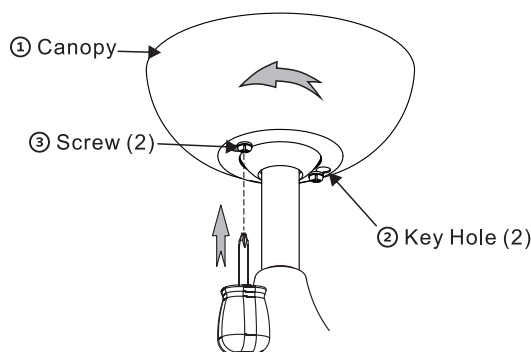

6. BLADE INSTALLATION

Attach blades to motor by using Screws and Washer provided from hardware bag.
(* Do this step for 3 times until 3 blades are installed firmly.)

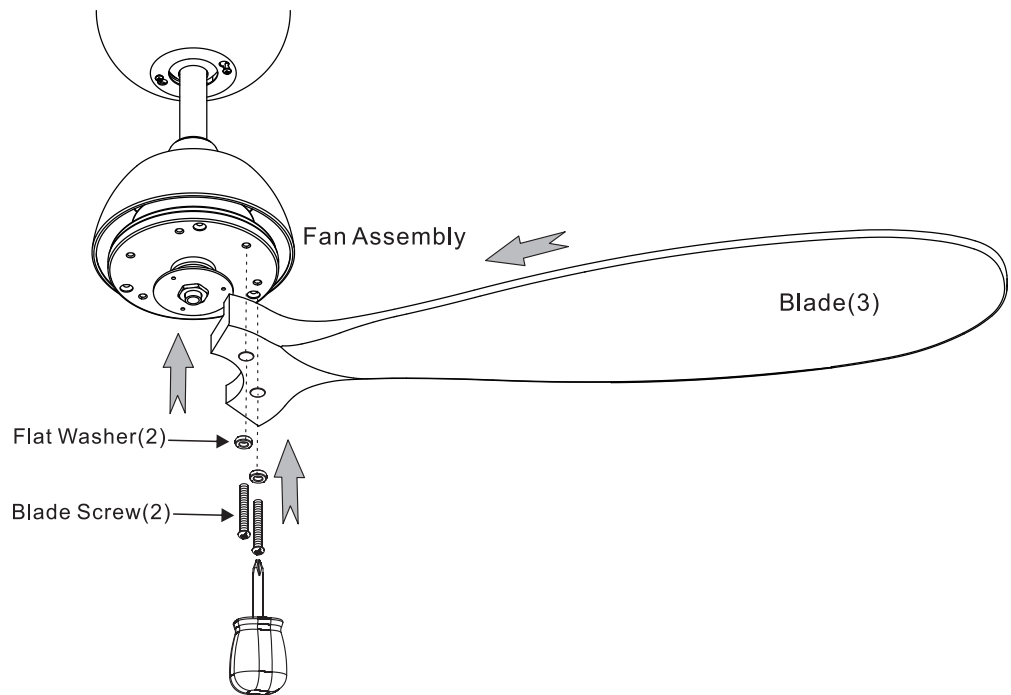

7. LED LIGHT KIT PAN ASSEMBLY INSTALLATION

① Remove one of 3 pre-screwed screws on adapter. (Keep the screw for step ⑤)

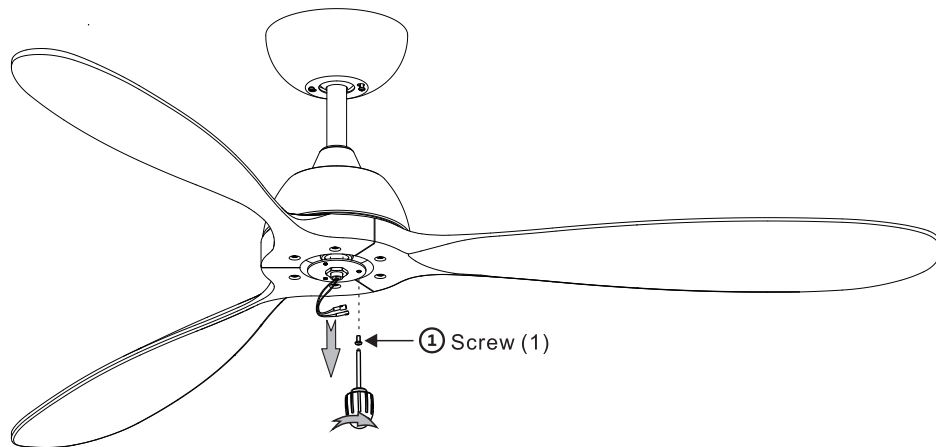

② Insert wires through center hole of LED Light Kit Pan Assembly.

③ Connect 2-pin male terminal connector from LED Light Kit Pan Assembly to 2 pin female connector from fan.

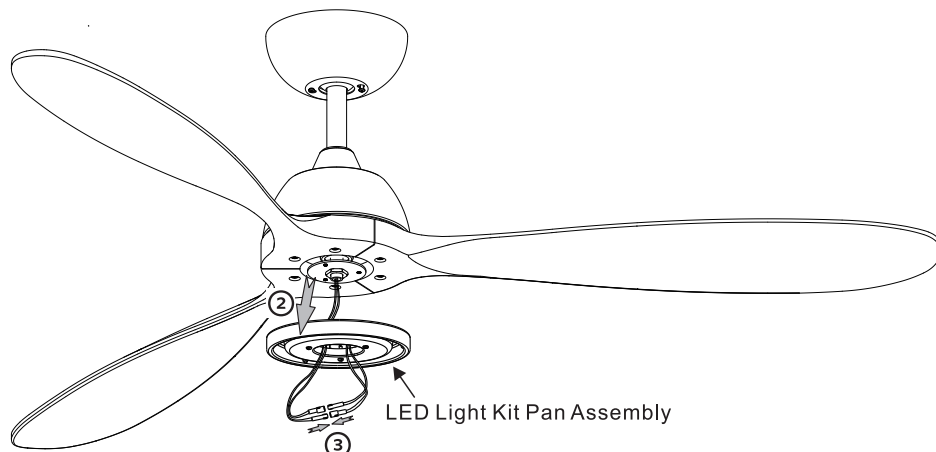

④ Rotate the Light Kit Pan slightly until two pre-installed screw heads are engaged in the narrow end of key holes.

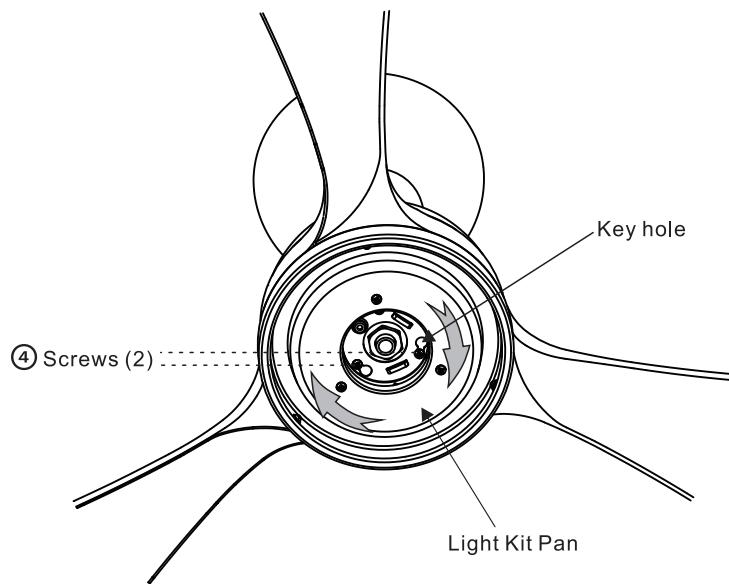

⑤ Attach screw (removed from step ①), and tighten 3 screws.

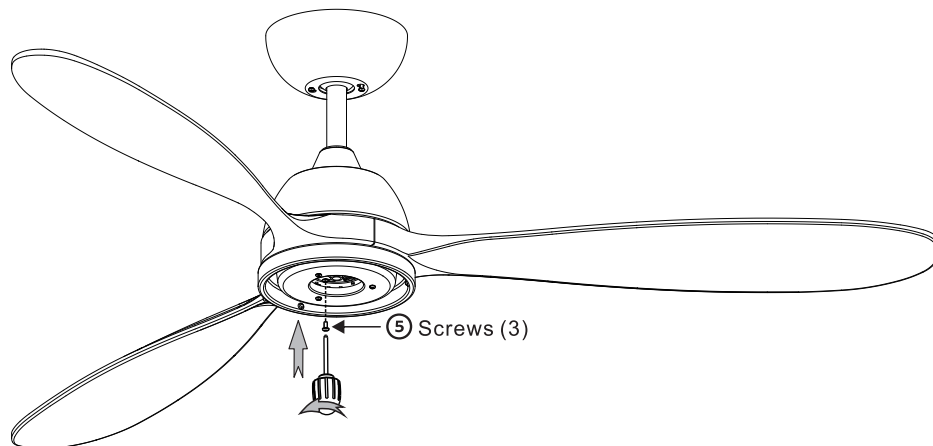

⑥ Attach Glass Shade onto the Light Kit Pan Assembly. Align one Groove in the Glass to one Tab on the Light Kit Pan Assembly. Secure by turning clockwise until snug. Do not over-tighten.

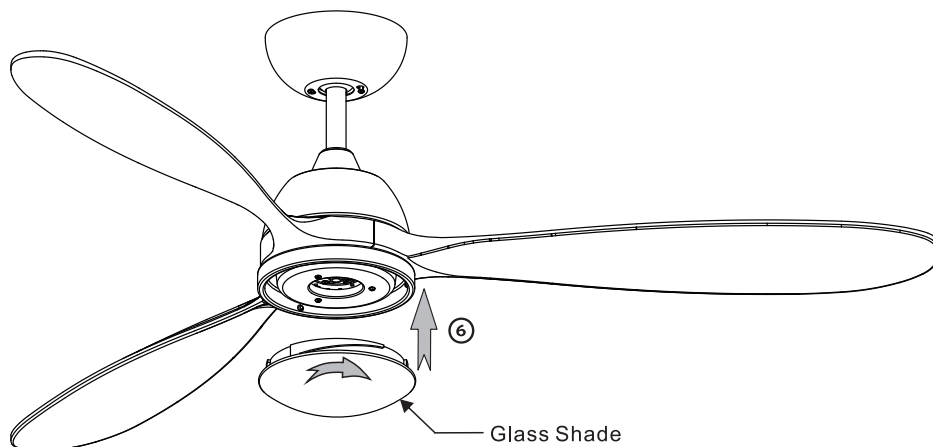

8.REMOTE TRANSMITTER ASSEMBLY

8-1. Remove the back cover

Remove the back cover by loosening screw.

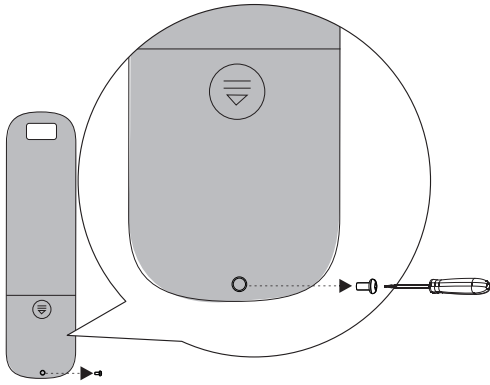

8-2. Install the battery

Install the 1.5V batteries.
(Included from remote box)

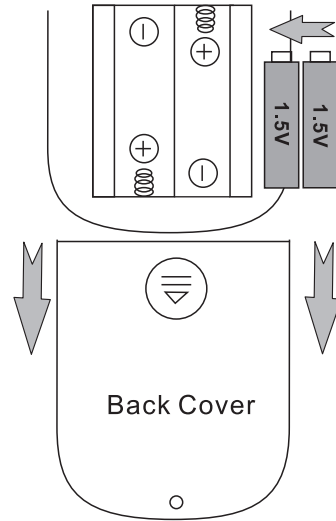

8-3. Re-install the back cover and fix by screw.

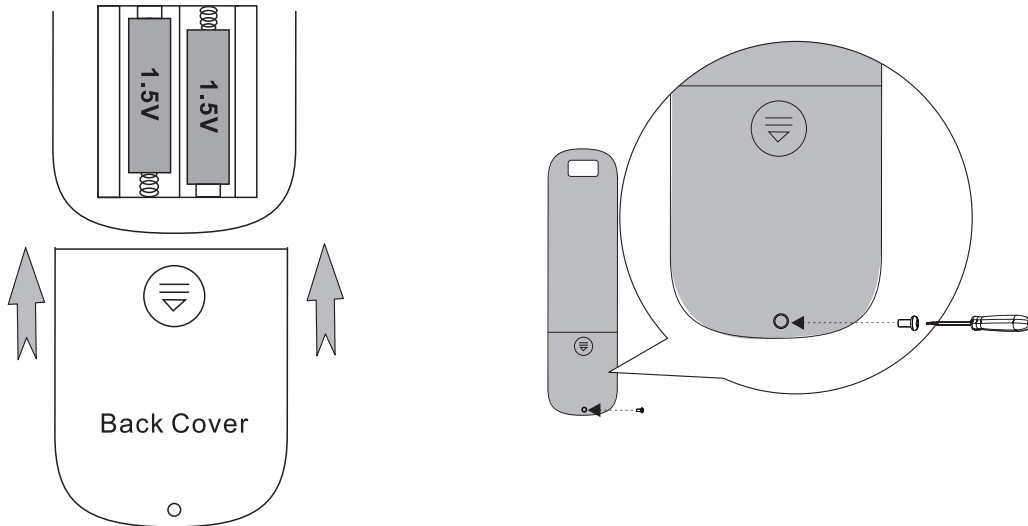

**Turn on power at breaker box, the fan is ready for operation!
(The receiver will have beep sound)**

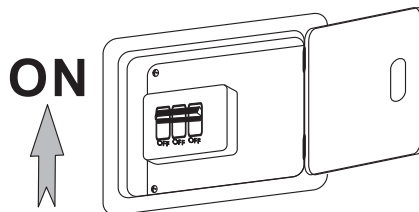

9. OPERATIONAL INSTRUCTION

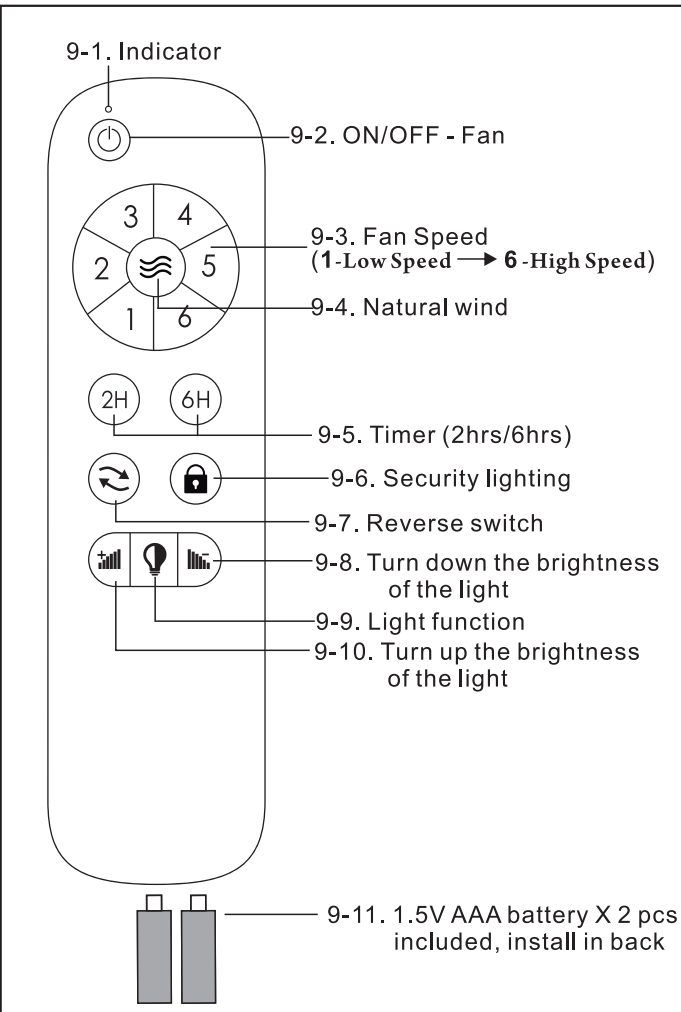

All the button pressed will have a Beep sound and the red indicator light will turn on.

9-1. Indicator
9-2. Press button to turn the fan ON/OFF.

Warning: DO NOT PRESS THE BUTTON FOR MORE THAN 4 SECONDS TO AVOID FACTORY RESET AND THE LOSS OF PRE-PAIRED PROGRAMING OF RECEIVER AND TRANSMITTER!

Note: On every startup, the fan will move forward & backward for 2~3 seconds.

- 9-3. Fan Speed: 1-Low Speed → 6 -High Speed
- 9-4. Natural wind
(The fan speed automatic cycle between 1 to 6 speed)
- 9-5. Timer
(2hrs/6hrs)
- 9-6. Security lighting
(The light ON about 5 minutes every 2 hours)
- 9-7. Reverse switch
- 9-8. Turn down the brightness of the light
- 9-9. Light On/Off
- 9-10. Turn up the brightness of the light
- 9-11. 1.5V AAA battery X 2 pcs included, install in back

Note: Press button to turn the fan ON/OFF. The remote retains the last settings (fan speed and light dimming level) in memory. Switch the fan ON/OFF by main power will operate at initial setting. (fan off and light on)

TROUBLESHOOTING

In the event the fan does not operate properly, please perform the following steps.

1. Lower the canopy and check that all wires are connected properly.
2. Perform the remote Pairing Process at step 10-1 on P10.

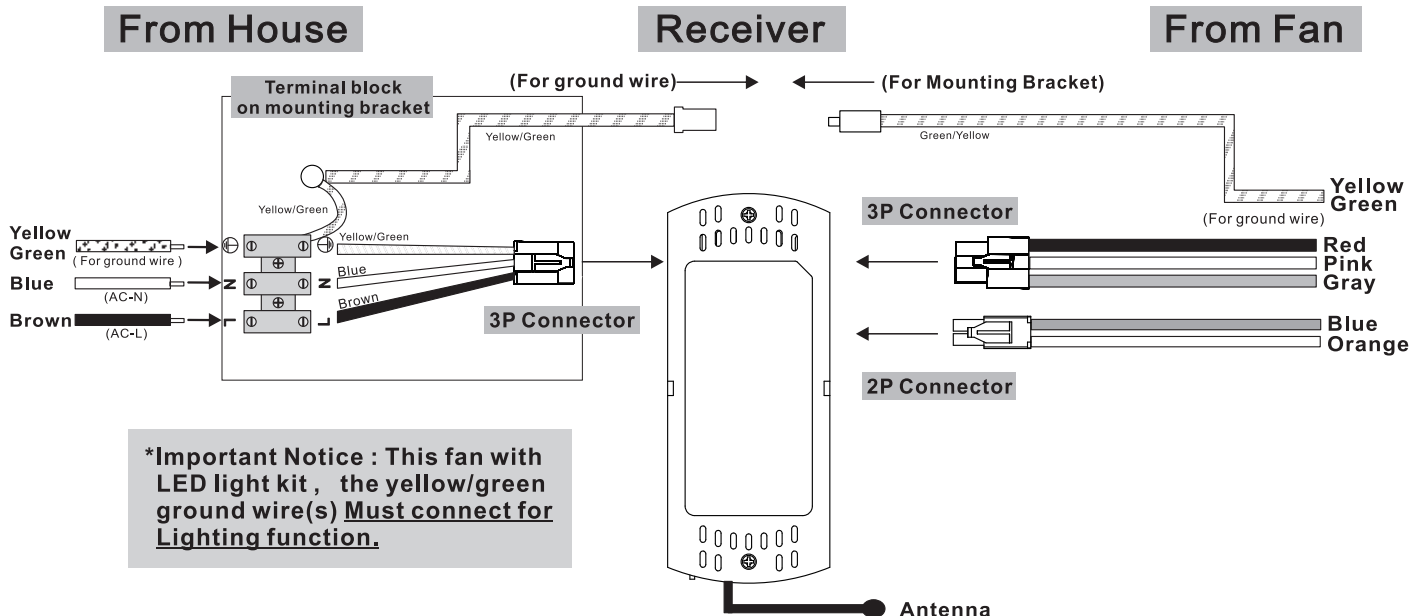

***Important Notice : This fan with LED light kit , the yellow/green ground wire(s) Must connect for Lighting function.**

10. REMOTE PAIRING PROCESS

The Pairing Process is only necessary when there is an issue. Remote set is pre-paired from the factory and should not require the Pairing Process.

A fan may need to have “Pairing Process” performed for the following issues.

1. Replacing the transmitter.
2. Replacing the receiver.
3. Multiple fans on the same circuit.

(In multiple fans situation, each fan must be wired up individually for the Pairing Process; **see step 10-1.**)

10-1. Pairing Process for transmitter and receiver:

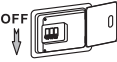
1. Switch off the main power  and make sure fan has completely stopped .
2. Install a New receiver or install the battery in a new transmitter before the Pairing Process.
3. Switch on the power again, and immediately:

Press and hold the  button for 8 seconds until the Receiver “Long Beeps”.

This process must be done within 20 seconds after switching on the power.

This fan has completed the pairing successfully and the fan is ready for operation!

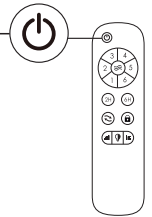

10-2A. Pairing Process for Multiple fans (One transmitter for multiple receivers)

If you wish to use only **one transmitter for two fans**, simply wire up both fans at one time and perform the Pairing Process at **step 10-1** from a point between the two fans.

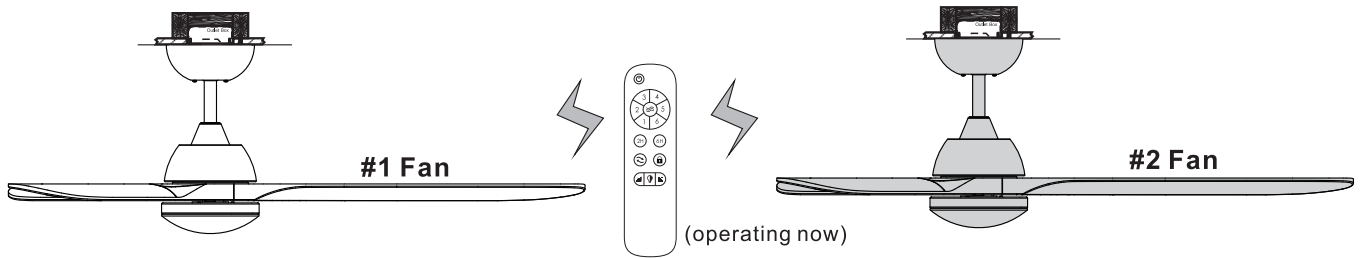

10-2B. Pairing Process for Multiple fans (One transmitter for one receiver)

The Pairing Process must be performed on each remote set (transmitter and receiver) individually. **See the set up at step 10-3.**

10-3. TO SET UP REMOTE FOR #1 FAN

Make sure to turn off power at breaker box. 
Disconnecting wire from #2 fan.

Before starting the remote control setting process, lower the canopy of #2 Fan and disconnect the Brown wire. Put the wire nut on the brown wire from the house.

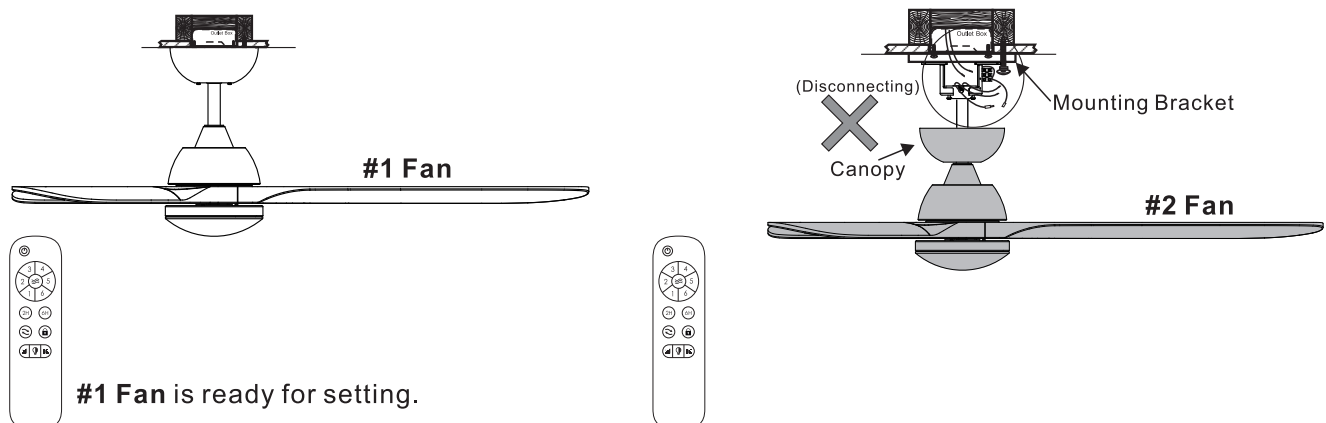

Turn on power at breaker box and #1 Fan is ready for pairing. 

*See the remote control setting process **10-1** to set up #1 Fan.

10-4. TO SET UP REMOTE FOR #2 FAN

Make sure to turn off power at breaker box.  OFF

Disconnecting wire from #1 Fan

Disconnect the Brown wires from #1 Fans and connect the Brown wires back to #2 Fan that you remove from 10-3.

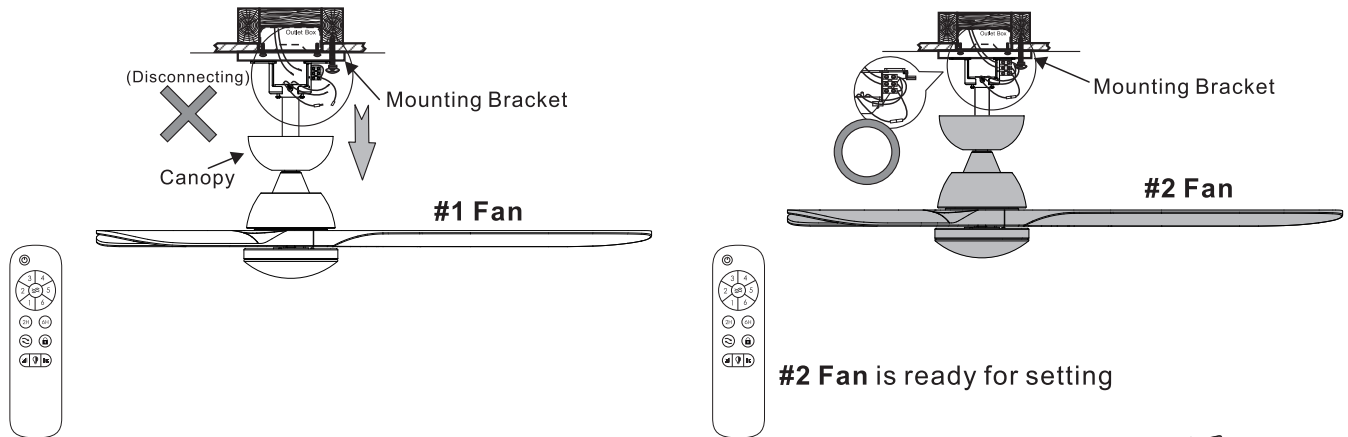

Turn on power at breaker box and #2 Fan is ready for setting.  ON

*See the remote control setting process for 10-1 to set up #2 Fan.

10-5. RECONNECT ALL FANS

Make sure to turn off power at breaker box.  OFF

After all the fans have done the resetting process, reconnect all the wires for #1 fan & #2 fan, and lift up the Canopy of #1 fan & #2 fan.

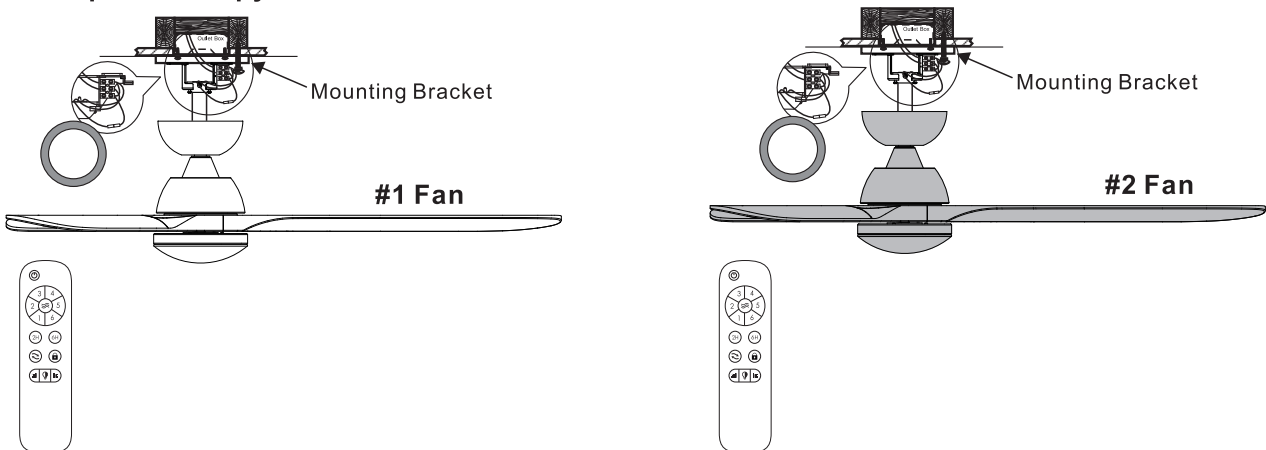

10-6. Switch on the main power and now each of these two fans are operated by its own remote individually.

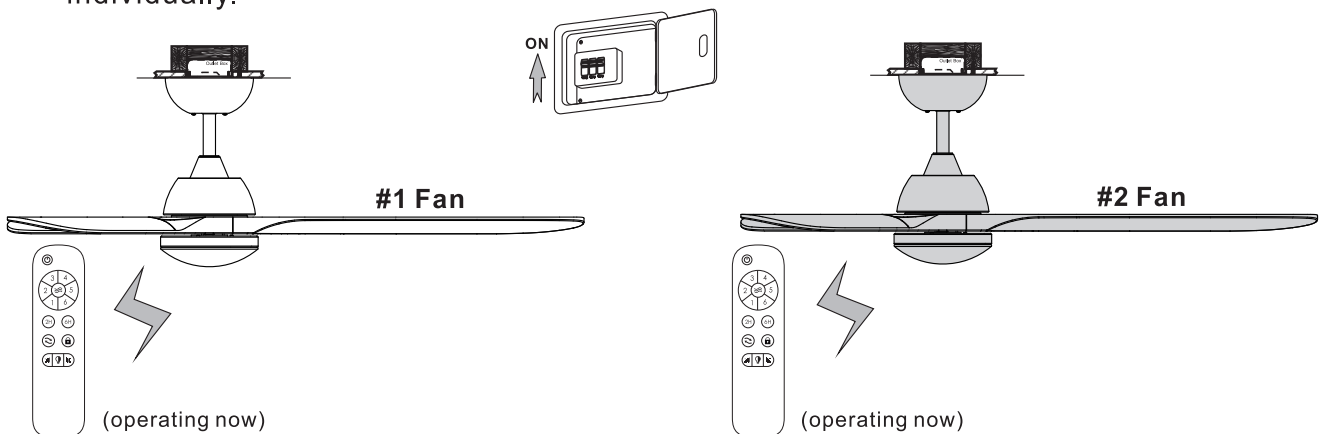

NOTE: For more than two fans, the same rules apply. Make sure only one fan at a time is connected to power when doing the Remote Setting. Already completed fans should be disconnected until all fans have completed the Remote Setting process.